

1–3
BR

Grades 1–3

Braille

ACCESS for ELLs[®]

**Sample Items User Guide
for Braille
UEB Contracted**

Braille Basics

This page contains general information about the braille student test booklet. It is primarily intended for test administrators who are not familiar with administering assessments in braille.

- Braille page numbers are on the bottom right corner of all odd pages. There are no braille page numbers on even pages.
- The corresponding print page number appears on the top right corner of all pages with any braille information on it. A letter designation is placed before the page number when multiple braille pages are used (e.g., 8, a8, b8).
- A single page of text in the print booklet may span multiple pages of braille.
- Pictures will appear as either a picture description (description in text), tactile graphic (graphic using a raised image), or a combination of both. Other times, the pictures have been completely removed.
- A dotted line going across the page is an indicator that material from two different pages of the print booklet appears on the same page of text.
- A double dotted line going across the page indicates the beginning or end of a table.

A	B	C	D	E	F	G	H	I	J	K	L	M
N	O	P	Q	R	S	T	U	V	W	X	Y	Z
1	2	3	4	5	6	7	8	9	0	capital follows	decimal follows	number follows
.	,	?	!	:	;	-	/	<	>	()	space

Using this document

Review these sample items to gain a better understanding of the look, feel, and process of the ACCESS for ELLs test. Use these items in any way that is helpful for you and your students. If practical for your classroom, WIDA strongly encourages you to use the sample test administrator script to do a full mock administration of the sample items, as a realistic administration can help prepare your students for the real test.

If you do plan a mock administration, read through this document and set aside adequate time to explain each activity and allow students to answer the questions.

- If you will be transcribing student responses, see the [Accessibility and Accommodations Manual](https://portal.wida.us/resource/detail/5fafc1fb-24ca-eb11-a2df-0050568beee8) (portal.wida.us/resource/detail/5fafc1fb-24ca-eb11-a2df-0050568beee8) for transcription information and guidelines.

You will find materials for mock administration in your Braille Kit.

Note: The items in this sample are for use with grades 1–3. While the sample items themselves are at a level for grades 2 and 3, they are similar in format and content to grade 1 items and will help prepare grade 1 students for the assessment. On the actual test, item difficulty will vary across grades 1–3.

How to read the script

The script includes text that is read aloud during test administration as well as directions for the test administrator:

- Read aloud all bold text. Instructions students hear are **black and bold**.
- Read aloud *italicized bold* text when necessary.
- Do NOT read unbolded text aloud. Unbolded text gives directions to the test administrator.

Read all bold text aloud.

Do NOT read this text aloud. All unbolded text serves only as a guide for the test administrator.

Read italicized black and bold text aloud when necessary.

This part says, “Part C.”

Scan the room and make sure all students are in the right place.

It says,

“What is happening in this picture?”

In this part, write about what the class is doing. Number 5 is done for you. What does it say?

Allow time for students to respond, or say: *It says, “The teacher is giving a pencil to a girl.”*

Look back at the big picture. Find the teacher giving a pencil to a girl. PAUSE.

What else is happening in the picture?

Allow time for students to respond.

1–3 Reading Sample Item: My Day at School

Explain to your students that they are about to complete a reading exercise. This exercise is similar to a test they will take in the future. The test will be their opportunity to demonstrate their English proficiency in reading, and this practice exercise will help them get ready for the test.

Set aside 30 minutes to explain the activity and allow students to answer the questions.

- Students are allowed to explore any graphics, charts, or tables before answering the questions.

When the students are ready and understand what they are going to do, pass out the test materials. Each student needs a complete copy of the sample test items and a braille writing tool.

Ask the students to write their name at the top of each page.

Read the following script to guide students through the sample items.

Find the page labeled “My Day at School” at the top. Rita made a chart to show her class schedule.

You are going to read this to yourself and answer the questions on your own. The directions and the table will help you understand the questions.

Some items on the Reading test may have picture descriptions, tables, or tactile graphics with labels. I will read picture descriptions aloud but am not able to read any test questions. I can also help you orient to tables.

Remember to write both the question number and your response for each question.

Do you have any questions?

Answer questions.

O.K., you may begin now.

Monitoring the test

As you walk around the room and monitor the students’ work, check to make sure that each question has been answered. Do not check whether responses are correct or not. If any responses are missing, point them out to the students and invite them to try again.

End the testing session by saying:

Good job. You have reached the end of the section. I will collect your papers.

1–3 Writing Sample Item: Melting Ice Cubes

Explain to your students that they are about to complete a writing exercise. This exercise is similar to a test they will take in the future. The test will be their opportunity to demonstrate their English proficiency in writing, and this practice exercise will help them get ready for the test.

Set aside 45 minutes to explain the activity and allow students to answer the questions.

- Students are allowed to explore any graphics, charts, or tables before answering the questions.

When the students are ready and understand what they are going to do, pass out the test materials. Each student needs a complete copy of the sample test items and a braille writing tool.

Ask the students to write their name at the top of the page.

Read the following script to guide students through the sample items.

Go to the page that says, "Part B: Melting Ice Cubes."

Scan the room and make sure all students are in the right place.

Now let's find the sentence at the top. It says,

"The following four pictures show what happened between 1:30 p.m. and 3:00 p.m. when solid ice melted into liquid water."

There is a transcriber's note. It says, "All temperatures shown are in degrees Fahrenheit."

Go to the page with the tactile graphics.

Find the picture that says one-thirty p.m. The temperature of the ice is thirty-two degrees. What do you notice in this picture?

Allow time for the students to respond, or say: *There are eight ice cubes in the container. The ice cubes are large, cold, and hard.*

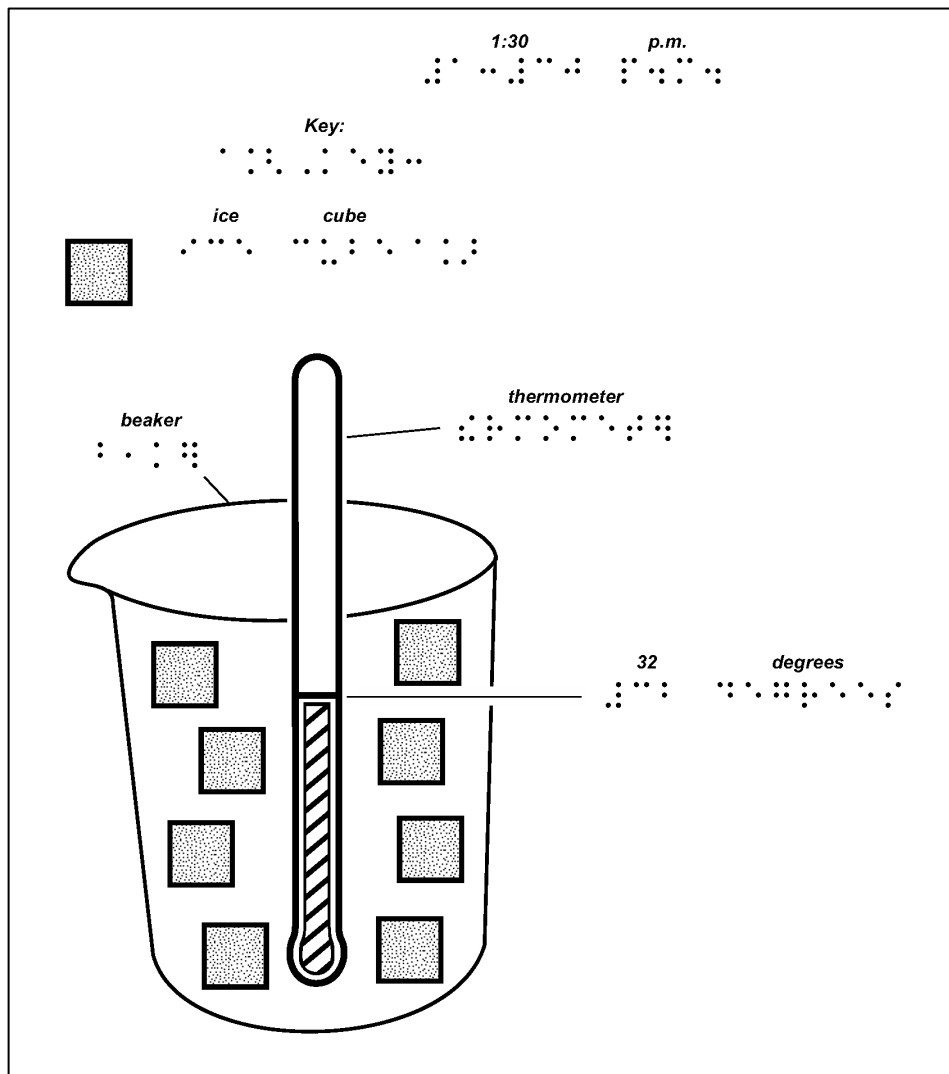

Find the picture that says one forty-five p.m. The temperature of the water is thirty-two degrees. Some ice cubes melted. There are six smaller ice cubes left.

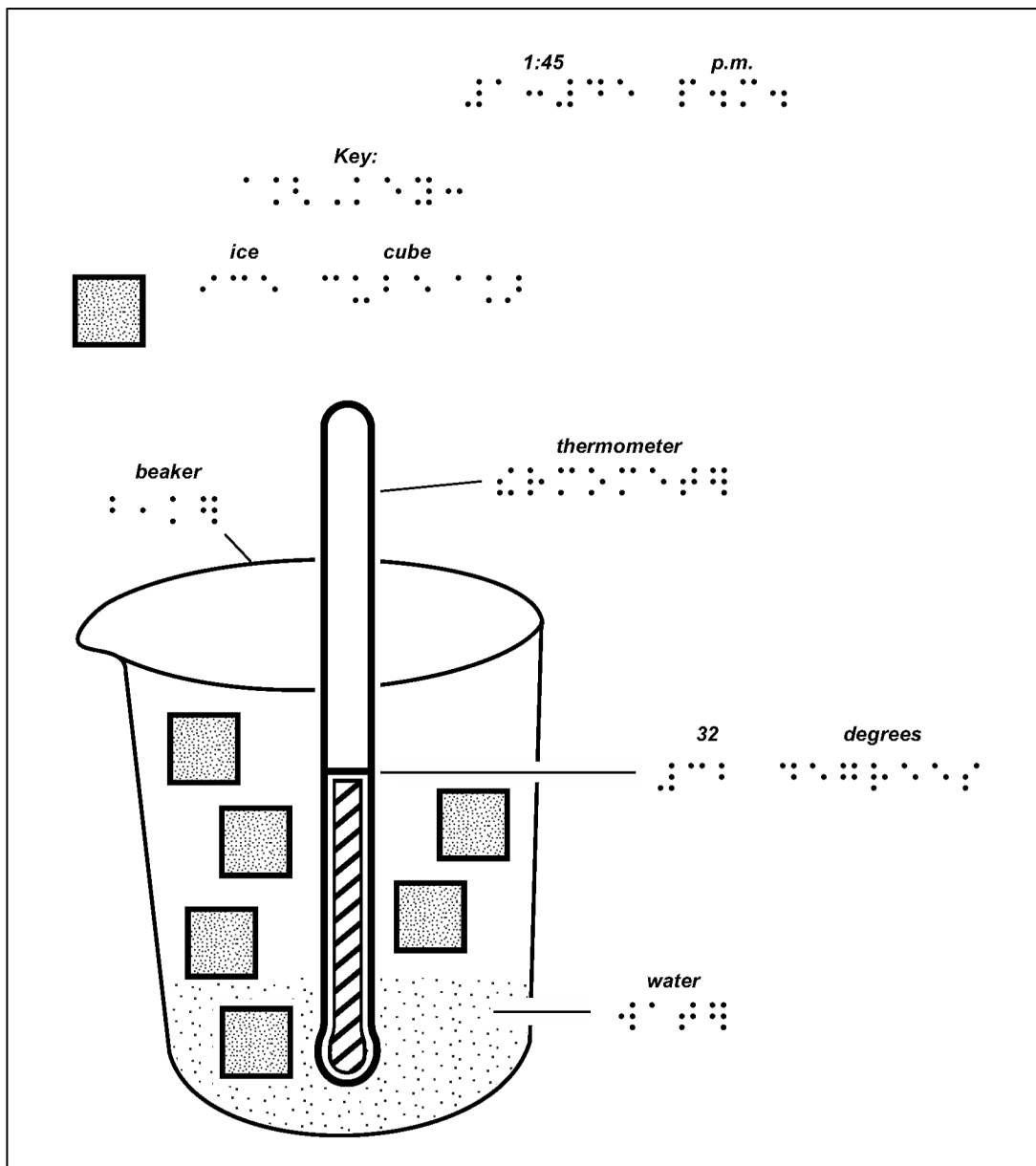

Find the picture that says two o'clock p.m. The temperature of the water is still thirty-two degrees. Now there is more water in the container. Almost all of the ice cubes have melted. Only four small ice cubes are left.

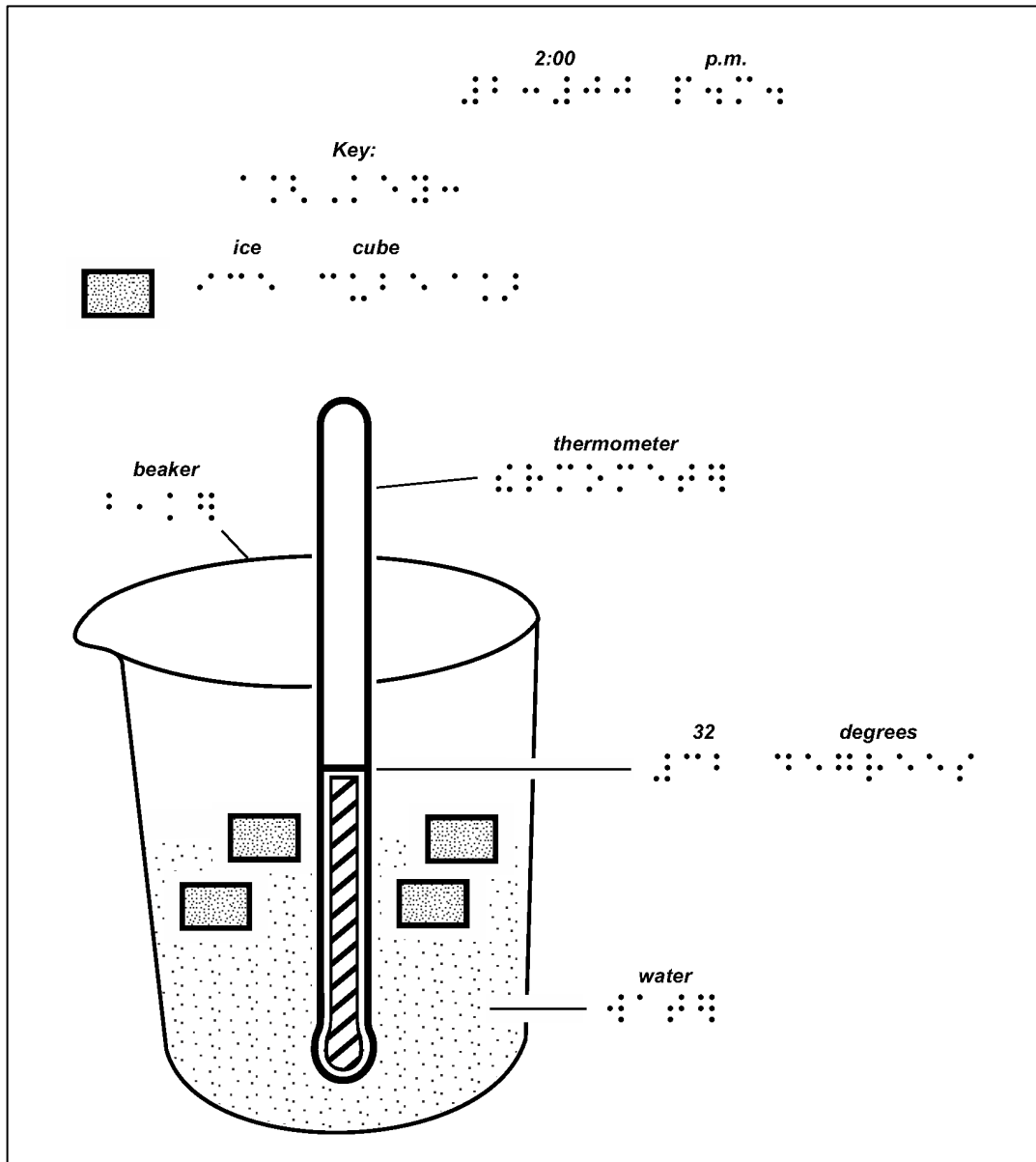

Find the picture that says three o'clock p.m. The temperature of the water is now fifty-five degrees. What do you notice in this picture?

Allow time for the students to respond, or say: *All of the ice cubes have melted into water. The temperature is higher now than it was at one thirty p.m.*

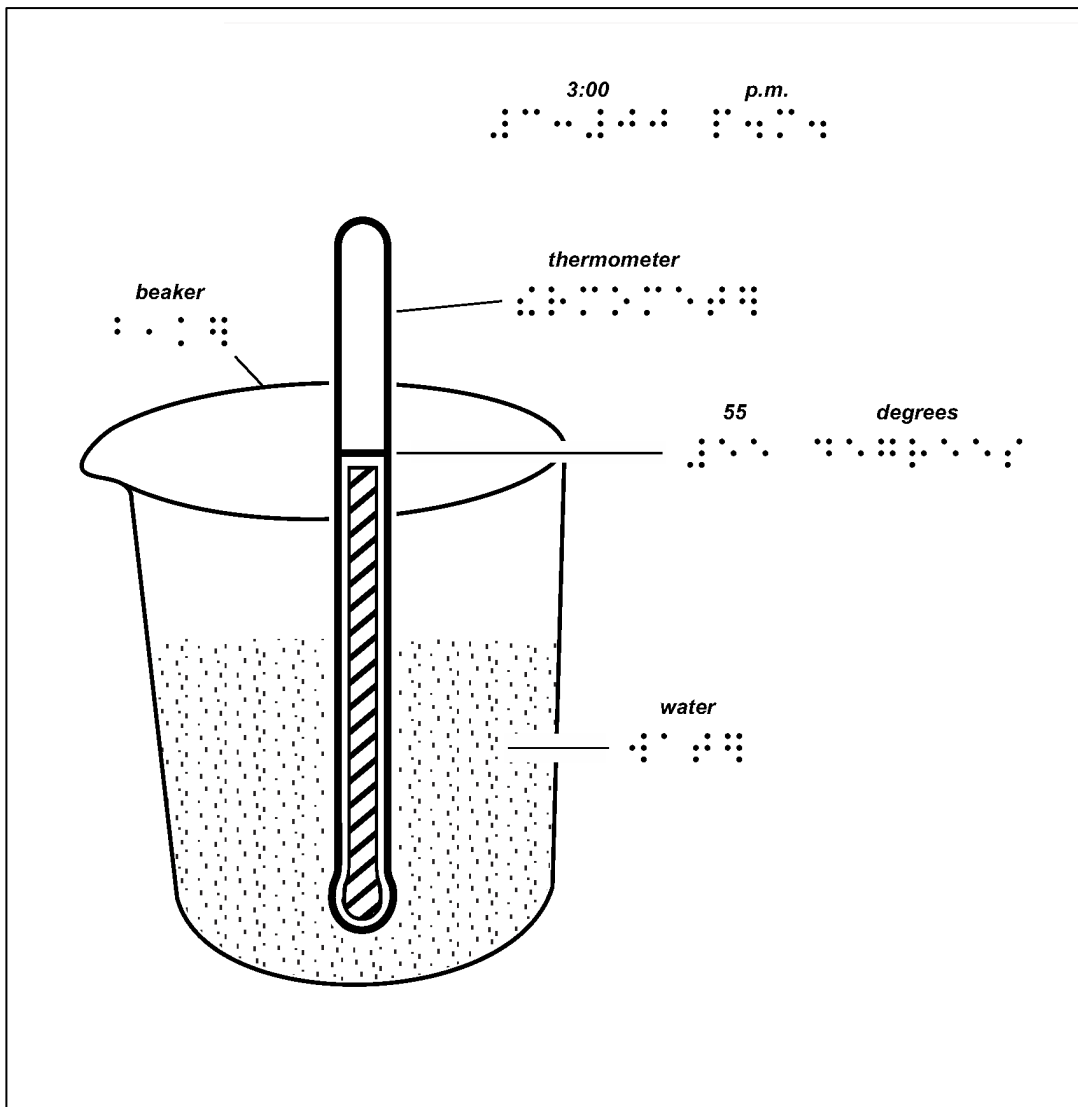

Do you have any questions about the pictures?

Answer questions.

Now go to the top of the next page. It says, "Now it's your turn to write!"

Scan the room to make sure all students are in the right place.

Find the directions. They say,

"Write 4 to 6 sentences to explain how water changed from a solid to a liquid between 1:30 p.m. and 3:00 p.m. You may use the pictures, the numbers, and the word list to help you write."

Now find the word list. The words are there to help you write. I'm going to read the words from top to bottom. Point to the words as I read them aloud. The words are:

“first, then, next, last, ice cubes, melt, cold, warmer, thermometer, temperature.”

Remember you can use the pictures and the writing on the other page to help you. You have about 20 minutes to write. Do you have any questions?

Answer questions.

Go back and check your work when you finish. When you get to the STOP sign, raise your hand. Now begin writing.

Monitoring the test

Monitor the students. Check to make sure everyone is following directions.

If any students are still working productively at the end of 20 minutes, say: ***Please finish what you are writing now.***
PAUSE.

End the testing session by saying:

Good job. You have reached the end of the section. I will collect your papers.

